

ARTICLE VI (ALTERNATE)
STANDARD SPECIFICATIONS
for
(PVC) SANITARY SEWER MAIN CONSTRUCTION

VI(A).1 General

VI(A).2 Materials and Equipment

VI(A).3 Installation of Sanitary Sewer Mains

VI(A).4 Laying of Pipe

VI(A).5 Backfilling

VI(A).6 Removal, Restoration, and Maintenance of Surface

VI(A).7 Cleanup

VI(A).8 Acceptance Testing

VI(A).9 Measurement and Payment

VI(A).10 Standard Drawings

ARTICLE VI (ALTERNATE)

STANDARD SPECIFICATIONS

for

(PVC) SANITARY SEWER MAIN CONSTRUCTION

VI(A).1 GENERAL

- A. The work covered by this Article VI (Alternate) of the specification consists in furnishing all labor, equipment, supplies and materials, and in performing all operations in connection with the construction of (PVC) sanitary sewer main and related appurtenances. The following recognized standards [State of Nebraska, Department of Roads 1985 Standard Specifications for Highway Construction (NDOR), the American Water Works Association Standards (AWWA), American Standards for Testing and Materials (ASTM), American Association of State Highway and Transportation Officials (AASHTO), etc. or the latest revisions thereof] shall apply except as hereinafter provided. All specifications included in this Article IV will pertain except that special notations on the plans, in the Special Provisions or in the General Provisions shall have precedence.

VI(A).2 MATERIALS AND EQUIPMENT

- A. Unless otherwise specified on plans or in the Special Provisions all materials furnished for work on this contract shall be new materials. No salvaged or revised materials shall be furnished.
- B. All Polyvinyl Chloride Pipe (PVC) supplied for this project shall meet the ASTM D-1784 & D-3034 requirements for Standard Dimension Ration (SDR) 35 pipe with push on type joints. Bidders shall state in their proposal the brand and type of pipe that they propose to furnish.
- C. All PVC joints shall be push on type rubber gasketed and shall meet ASTM D-3212 and/or F-477 requirements.
- D. All ductile iron pipe shall be manufactured in accordance with the requirements of AWWA Standard C151/A21.51. The pipe thickness shall be designed in accordance with AWWA Standard C150/A21.50. All pipe will have a cement mortar lining in accordance with AWWA Standard C104/A21.4, and the joints shall conform to AWWA Standard C111/A21.11 for mechanical and push-on joints. Unless otherwise specified all pipe shall be Class 52.

Revised 1/2007

- E. All ductile iron/gray iron shall be manufactured in accordance with the requirements of AWWA Standard C110/A21.10. Unless otherwise specified all fittings shall be Class D and shall be cement mortar lined.
- F. All concrete entering into the work unless otherwise specified shall be sand-gravel concrete as specified by NDOR specifications for ABX Concrete.
- G. All manholes shall be precast concrete with a minimum wall thickness of 5" and shall be manufactured to comply with ASTM C-478 except as follows:
 - a. The taper section shall be a maximum of 3 feet in height.
 - b. The throat section shall not exceed 18 inches in height.
 - c. An approved plastic bituminous compound may be used in making the joints of the precast manhole rings in locations where ground water is not a problem. This material shall be "Tufflex", "Plastico", or other approved equal.
- H. All sewer brick supplied for this project shall conform to ASTM C32, Grade MA.
- I. All Gray Iron Casting shall conform to ASTM A-48, Class No. 35, and shall be of the type and quality or an approved equal as follows:
 - a. Manhole Ring and Cover Deeter 1030.
 - b. Cleanout Ring and Cover Deeter 1810.
- J. All cement mortar shall conform to ASTM C270, Type M.
- K. Joints between different types of pipe materials shall be made using a flexible coupling made of elastomeric plastic with stainless steel clamps (commonly referred to as "Fernco" couplers).
- L. All PVC pipe shall be bedded in gravel meeting the following gradation requirements:

Total Percent Retained on Sieve

Seive	Target Value	Tolerance
1 inch	0%	NONE
No. 4	40%	+/- 20%
No. 10	83%	+/- 15%
No. 200	96%	+/- 4%

VI(A).3 INSTALLATION OF SANITARY SEWER MAINS

- A. PVC pipe, fittings, precast manholes, and accessories shall be loaded and unloaded by lifting with hoists or skidding so as to avoid shock or damage. Under no circumstances shall such materials be dropped. Material handled on skidways shall not be skidded or rolled against pipe already on the ground. In distributing the material at the site of the work, each piece shall be unloaded opposite or near the place where it is to be laid in the trench.
- B. The sanitary sewer main shall be laid and maintained to the required lines and grades with manholes set at the required locations and at the proper grades. Bell holes shall be provided at each joint to permit the jointing to be made properly.
- C. All manholes shall be constructed of precast concrete rings and poured in place bases unless otherwise authorized or directed. The flow line of the manhole shall be grouted smooth and slope towards the channel at 1 1/2 inches per foot plus or minus 1/2 inch per foot. The invert of the channels shall be smooth and semicircular in shape and changes in direction of flow shall be made using smooth long radius curves. A gasketed flexible watertight connection shall be used between the sewer pipe and the manhole wall.
- D. Wherever existing utility structures or branch connections leading to them (including but not limited to sanitary sewers, storm sewers, water lines, gas lines, electrical lines, telephone lines, cable TV lines etc.) present an obstructions to the grade and alignment of the pipe, they shall be permanently supported, removed, relocated or reconstructed by the Contractor or through cooperation with the Owner of the utility, structure or obstruction involved. In instances where location or reconstruction is impractical, a deviation from line and grade will be ordered and the change shall be made in the manner directed. No deviation shall be made from the required line or grade except with the written consent of the Engineer.
- E. The Contractor shall proceed with caution in the excavation and preparation of the trench so that the exact location of underground structures, both known and unknown, may be determined, and he shall be held responsible for the repair of such structures when broken or otherwise damaged because of carelessness on his part.
- F. Whenever, in the opinion of the Engineer, it is necessary to explore and excavate to determine the location of existing underground structures, the Contractor shall make explorations and excavations for such purposes.

- G. The trench shall be dug so that the pipe can be laid to the alignment and depth required and only so far in the advance as the Engineer shall permit. The width of the trench shall be ample to permit the pipe to be laid and jointed properly, the backfill to be placed and compacted as specified, and the workmen to work therein safely and efficiently. Wherever necessary to prevent caving, excavations in unstable material (such as sand, gravel or sandy soil) shall be adequately sheeted and/or braced so that workmen may work therein safely and efficiently. Where sheeting and/or bracing is used the trench width shall be increased accordingly, and the sheeting and/or bracing shall also allow for the handling of specials (i.e. manholes or service lines). Trench sheeting shall remain in place until the pipe has been laid and the earth around it compacted to a depth of two feet over the top of the pipe. The cost of furnishing, placing and removing the sheeting and bracing, and the leaving in place of sheeting and bracing indicated on the plans, shall be included in the price bid for the work.
- H. The Contractor shall be required, at his own expense, to keep trenches free from water during progress of the work unless otherwise indicated on the plans or in the Special Provisions. It is essential that the discharge of the trench dewatering pumps be conducted to natural drainage channels, drains or storm sewers. Under no circumstances will the Contractor be permitted to discharge to the City's sanitary sewer system.
- I. The trench shall be excavated to the depth required so as to provide a uniform and continuous bearing and support for the pipe on solid and undisturbed ground conforming to the required grade. Any part of the bottom of the trench excavated below the specified grade shall be corrected with approved material thoroughly compacted as directed by the Engineer. The finished subgrade shall be prepared accurately by means of hand tools.
- J. When the trench bottom at the required grade is soft and in the opinion of the Engineer, cannot support the pipe, a further depth shall be excavated as directed and refilled with approved material thoroughly compacted, or other approved means shall be adopted to assure a firm foundation for the pipe. Extra compensation shall be allowed for the extra work required.
- K. All surface materials which, in the opinion of the Engineer, are suitable for reuse in restoring the surface shall be kept separate from the general excavation material, as directed by the Engineer.
- L. All excavated material shall be piled in a manner that will not endanger the work or the movement of traffic and that will avoid obstructing sidewalks and driveways. Hydrants under pressure, valve pit covers, valve boxes, curb stop boxes, fire and police call boxes, or other utility controls shall be kept unobstructed and accessible. Gutters shall be kept clear or other satisfactory provisions made for street drainage, and natural water courses shall not be obstructed.
- M. To protect pedestrians, direct and control vehicular traffic, and prevent damage to property, the Contractor shall provide safety devices in accordance with the Manual on Uniform Traffic Control Devices (1988 edition or the latest revision thereof). The Contractor is also

responsible for maintenance of these devices including updating/changing them to accommodate the changes of the construction area. In addition, the Contractor shall enclose all material piles, equipment and pipe which may serve as obstructions to traffic (pedestrian or vehicular) by fences or barricades and when the visibility is poor, lights shall also be used.

- N. The Contractor shall carry on the work in a manner which will cause the least interruption to traffic, and may close to through traffic not more than two consecutive blocks, including the cross street(s) intersected. Where traffic must cross open trenches, the Contractor shall provide suitable bridges at street intersections and driveways.
- O. Temporary support, adequate protection and maintenance of all underground and surface structures, drains, sewers and other obstructions encountered in the progress of the work shall be furnished by the Contractor at his expense and under the direction of the Engineer. The structures which may have been disturbed shall be restored upon completion of the work.
- P. Trees, shrubbery, fences, poles and all other property and surface structures shall be protected unless their removal is shown on the plans or authorized by the Engineer. When it is necessary to cut roots and tree branches, such cutting shall be done under the supervision and direction of the Engineer.

VI(A).4 LAYING OF PIPE

- A. PVC pipe shall be installed in accordance with ASTM Standard D-2321.
- B. Proper implements, tools and facilities satisfactory to the Engineer shall be provided and used by the Contractor for the safe and convenient prosecution of the work. All pipe and fittings shall be carefully lowered into the trench piece by piece by means of a derrick, ropes or other suitable tools or equipment, in such a manner as to prevent damage to sanitary sewer main materials. Under no circumstances shall equipment or materials be dropped or dumped into the trench. Before the pipe is laid, the outside of the spigot and the inside of the bell shall be wiped clean and dry, free from oil and grease.
- C. Precautions shall be taken to prevent foreign material from entering the pipe during laying operations. No pipe shall be laid in water or when, in the opinion of the Engineer, trench conditions are unsuitable. Methods used to accomplish this shall be approved by the Engineer. No tools, clothing, debris or other material shall be placed inside the pipe.
- D. After placing a length of pipe in the trench, the spigot end shall be centered in the bell and the pipe forced home and brought to correct line and grade. The pipe shall be secured in place with approved backfill material tamped under it except at the bells.
- E. Pipe laying shall proceed up the grade with the bell ends on the up stream end. At times when pipe laying is not in progress, the open ends of pipe shall be closed by a watertight plug or other means approved by the Engineer.

- F. The Contractor will not be permitted to deflect the joints of pipe laid on this project unless prior approval is obtained from the Engineer in writing.
- G. Unless specifically called for on the plans or in the special provision the only wye branches "Y's" shall be used where service lines are connected to the mains (tee branches "T's" will not be permitted). All service lines shall be installed according to the applicable requirements of this Article VI(A).
- H. All sewer service lines shall be capped and the capped end of the sewer service line shall be a minimum depth of 8 1/2 feet unless otherwise noted on the plans or unless the main line does not have sufficient depth. The minimum allowable grade for a service line is one-fourth (1/4) inch per foot.
- I. The location of the end of each service line shall be marked by placing a 2" x 2" wood stake. The stake shall extend from the sewer line cap to a point twelve inches above ground level. The top 2 feet of the stake shall be painted with one heavy coat of outside green house paint.

VI(A).5 BACKFILLING

- A. All backfill must be compacted to a minimum of 90 percent of the maximum dry density as determined by (AASHTO T99, ASTM D698) Standard Proctor. The Contractor shall backfill from the bottom of the trench (a minimum of 4 inches below the pipe) to the top of the pipe with approved bedding material (as outlined in paragraph VI(A).2.L of this Article VI(A) and, and the balance of the trench shall be backfilled using suitable material from the excavation. The top 12 inches of backfill in locations under existing or future pavement shall be compacted to a minimum of 96 percent of the maximum density as determined by (AASHTO T99, ASTM D698) Standard Proctor.
- B. Under existing or future pavements the Engineer may require that the backfill shall be placed and compacted in lifts of eight (8") inches maximum loose thickness.
- C. The Contractor shall bring all backfill material to not more than 4% above or 2% below the optimum moisture content before backfilling as determined by (AASHTO T99, ASTM D698) Standard Proctor.
- D. Tamping machinery and equipment shall be as approved by the Engineer. Machines too light for achieving the desired compaction and those that might damage the pipe will not be approved. The method of using the machines must also be as approved by the Engineer.
- E. The Owner may hire a recognized testing laboratory to perform in-place density tests on the subgrade.
- F. When in-place density tests are performed, the tests shall be performed in accordance with the procedures set forth in:

ASTM D 2167 (Rubber Balloon Method)
ASTM D 1556 (Sand Cone Method)
ASTM D 2922 (Nuclear Method)

- G. If the tests show non-compliance with the plans and specifications, the backfill shall be removed, replaced, and retested by the Contractor without extra compensation and at no extra cost to the Owner.

VI(A).6 REMOVAL, RESTORATION, AND MAINTENANCE OF SURFACE

- A. The Contractor shall remove pavement and road surfaces as a part of the trench excavation, and the amount removed shall depend upon the width of trench specified for the installation of the pipe and the width end length of the pavement area required to be removed for the installation of gate valves, specials, manholes, or other structures.
- B. The Contractor shall use a concrete saw cutting to a depth one-half the thickness of the slab to assure the breaking of the pavement along straight lines. The face of the remaining pavement shall be vertical and undamaged.
- C. If the Contractor removes or damages pavement or surfaces beyond the limits specified above, such pavement and surfaces shall be replaced or repaired at the expense of the Contractor to the satisfaction of the Engineer.
- D. The Contractor shall replace all surface material, and shall restore paving (unless otherwise specified), curbing, sidewalk, gutters, shrubbery, fences, sod and other surfaces disturbed, to a condition equal to that before the work began, furnishing all labor and material incidental thereto. The subgrade for the new pavement must first be approved by the Engineer prior to placing concrete. No pavement shall be replaced until backfill compaction has been approved by the Engineer.
- E. Surplus material, tools and temporary structures shall be removed by the Contractor, and all dirt, rubbish, and excess earth from excavation shall be hauled away by the Contractor, and the construction site shall be left clean, to the satisfaction of the Engineer.
- F. Following the certification of completion by the Engineer, the Contractor shall maintain the surface of the unpaved trenches, curbs, sidewalks, gutters, shrubbery, fences, sod, and other surfaces disturbed for the period described in the General Provisions.
- G. All material and labor required for the maintenance of the trenches and adjacent structures shall be supplied by the Contractor and the work shall be done in a manner satisfactory to the Engineer.

VI(A).7 CLEANUP

- A. When the installation of the sanitary sewer system is completed on any given section of sewer, the Contractor shall remove all material, equipment, temporary structures, trash and debris resulting from the construction from the project. The construction area shall be left in a neat and uncluttered condition. All sewer lines and force mains shall be flushed with water if required to remove all dirt, trash, and debris from the sewers and manholes. The Contractor shall furnish all water and flush the sewer line and force mains until lapping of the lines shows the pipe is clean. Dirt and debris shall not be flushed into other sewage lines or into waste treatment plants.

VI(A).8 ACCEPTANCE TESTING

- A. Prior to acceptance the Contractor shall perform a low pressure air test, a deflection test, and lapping of all sewer line constructed on this project. The cost of the testing shall be considered subsidiary to the installation of sewer pipe for which payment is made.
- B. The Contractor shall provide all materials, labor, and equipment to perform the required tests. The tests shall be performed in the presence of the Engineer or his representative.
- C. The low pressure air test will be performed on all sewer line constructed under this project (including all service lines). The test shall take into account the existing groundwater elevation.
- D. Air Pressure acceptance testing of sewer pipe shall conform to ASTM Standard F-1417.

Pipe Size, Inches	Required Time per 100 Lineal Feet (Minutes)
4	3:46
6	5:40
8	7:34
10	9:26
12	11:20
15	14:10
18	17:00
21	19:50
24	22:47
27	28:51
30	35:37
33	43:05
36	51:17

- E. Deflection testing shall be conducted on all sewer mains constructed on this project. The purpose of the deflection test is to assure that the pipe deflection does not exceed 5% reduction in the vertical inside diameter.
- F. A mandrell of precise outside dimensions representing a maximum of 5% reduction of the inside dimension of the pipe shall be freely pulled through each section of main after completion of the backfilling.
- G. Lamping of each section of sewer main constructed on this project will be conducted by the Engineer or his representative. A light shall be visible through each section of sewer main (manhole to manhole).
- H. If any section fails a test or tests the Contractor shall locate and correct the defect and retest until the section passes. No additional payment will be made for this additional work.

VI(A).9 MEASUREMENT AND PAYMENT

- A. All lines shall be measured along the centerline of the pipe through all fittings and manholes. Payment shall be based on the unit bid price as shown on the bidder's proposal. This payment shall constitute full compensation for materials, labor, and equipment to completely install the pipe, including trenching and backfilling.
- B. Measurement and payment for manholes shall be by unit each, or by the unit vertical foot as measured from the invert of the sewer to the bottom of the cast iron ring, depending upon the units used on the bid proposal sheet. This payment shall constitute full compensation for all labor and material to completely install the manhole, except ring and cover.
- C. Measurement and payment for cleanouts shall be by unit each and payment shall be at the unit bid price. Such payments shall constitute the material and labor required to completely install the cleanout as shown on the plans and drawings this includes the cost for the pipe to the surface and the ring and cover.
- D. Measurement and payment for cast iron rings and covers (manholes and cleanouts) shall be by unit each and payment shall be the unit bid price for the cover installed.
- E. Measurement for Wye, Branches, Tees and Plugs shall be by unit each, and payment at the unit bid price.
- F. No separate payment shall be made for manhole stub-outs, except that the pipe required to make these "stub-outs" shall be paid for as in paragraph VI(A).10.A
- G. Other items shall be measured in the units shown on the bid proposal, and payment shall be based on the number of units, such payment to constitute full payment for the item installed complete.

VI(A).10 STANDARD DRAWINGS

Typical Manhole.....Page VI(A).12

Drop Inlet Type Manhole.....Page VI(A).13

Special Manhole Construction for
High Ground Water or Unstable Soil.....Page VI(A).14

Sanitary Sewer - Water Main Crossing.....Page VI(A).15

Typical Cleanout.....Page VI(A).16

Typical Sanitary Sewer Service Line
InstallationPage VI(A).17

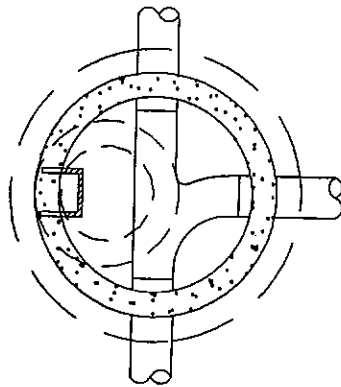

NOTES:

1. MANHOLE (PRECAST) REINFORCEMENT SHALL MEET A.S.T.M. C-478 REQUIREMENTS
2. MANHOLE JOINTS & LIFT HOLES SHALL BE SEALED WITH PORTLAND CEMENT MORTAR OR APPROVED EQUAL.
3. MANHOLE STEPS SHALL BE ALUMINUM OR COATED STEEL STEPS MEETING O.S.H.A. REQUIREMENTS.
4. MANHOLE RING & COVER SHALL BE DEETER #1030 OR APPROVED EQUAL.

TYPICAL FLOOR PLAN

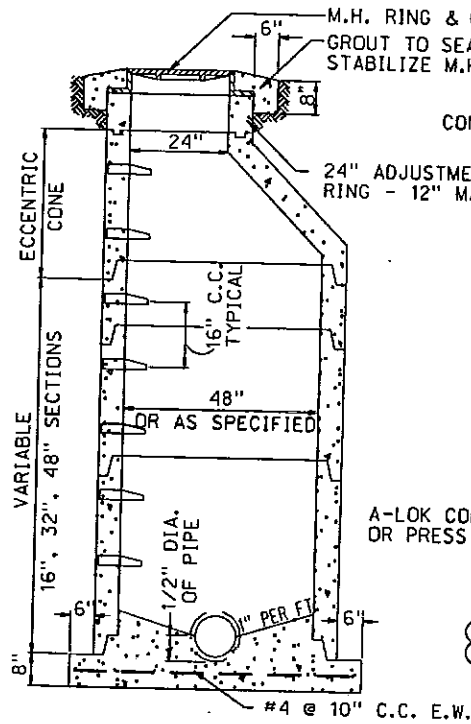

MANHOLE SECTIONAL ELEVATION

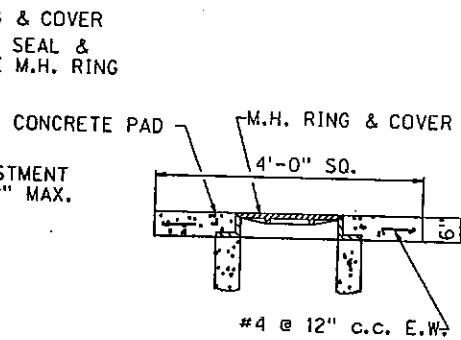

SURFACE MANHOLE RING & COVER INSTALLATION

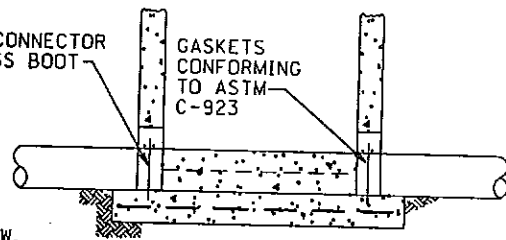

PIPE SECTION THROUGH MANHOLE

SANITARY SEWER MANHOLE

DEETER
1030

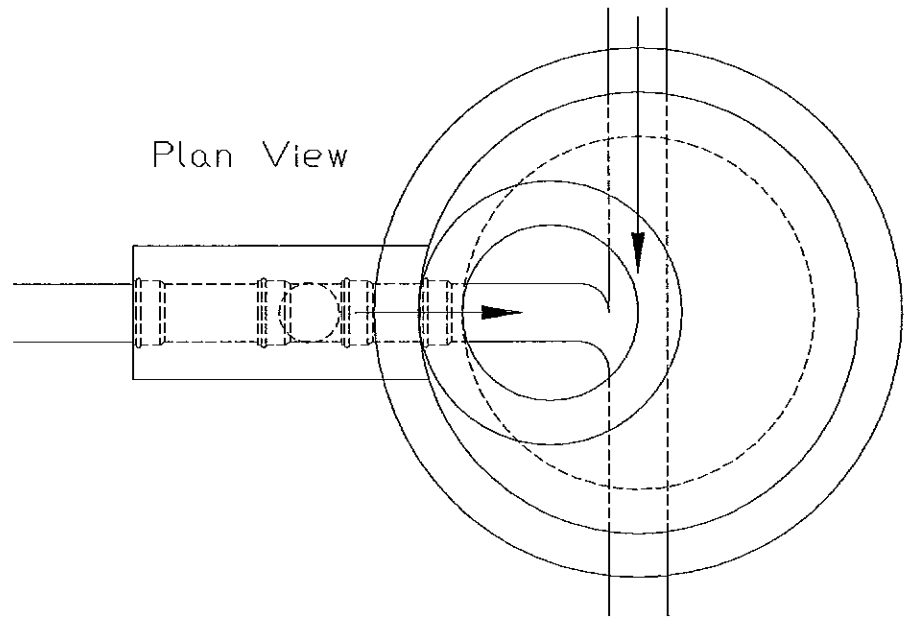
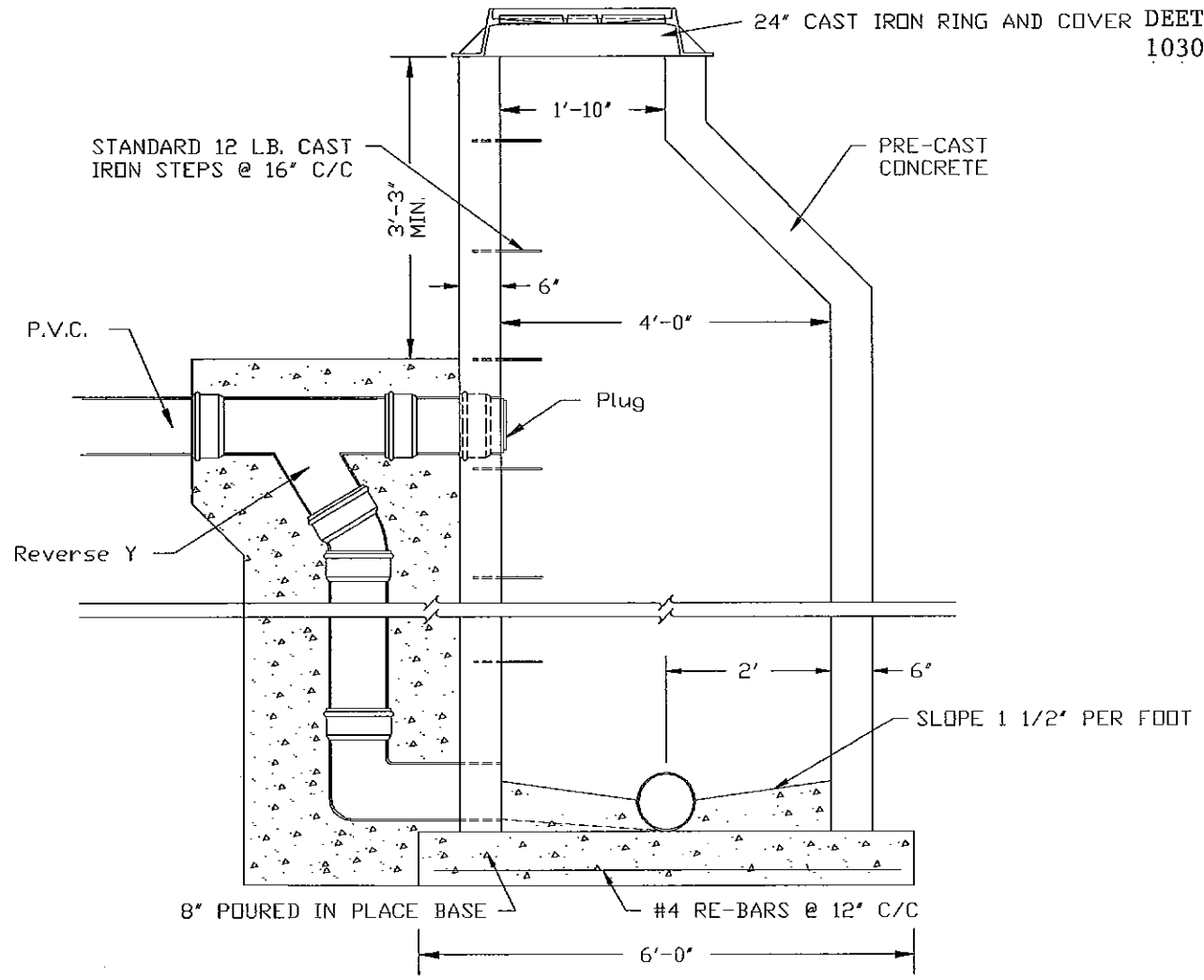

SECTION A-A

DROP INLET TYPE MANHOLE

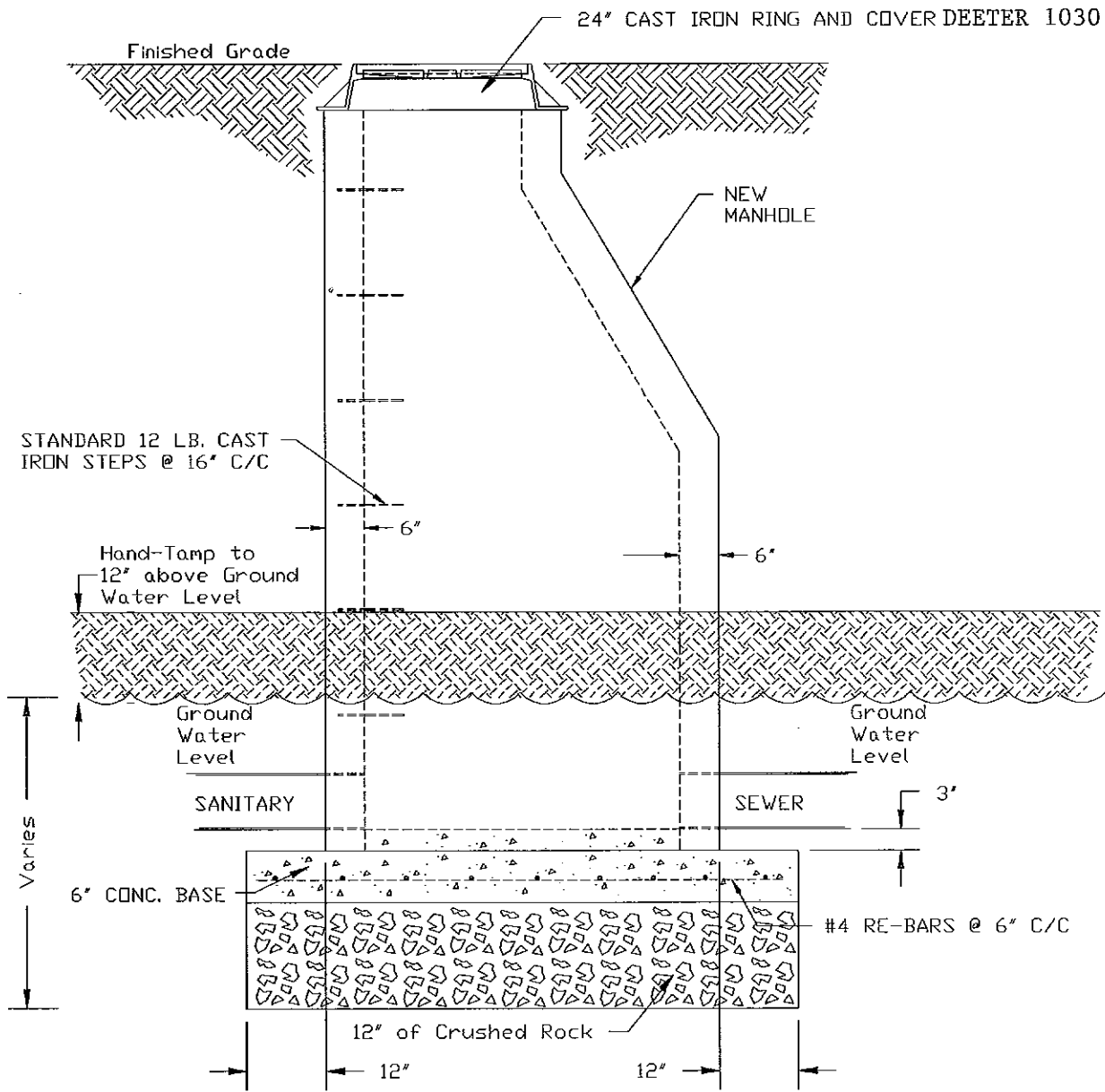

SPECIAL MANHOLE
 CONSTRUCTION
 FOR
 HIGH GROUND WATER
 AND / OR
 UNSTABLE SOIL

SANITARY SEWER - WATER MAIN CROSSINGS

SANITARY SEWER CROSSING OVER WATER MAIN

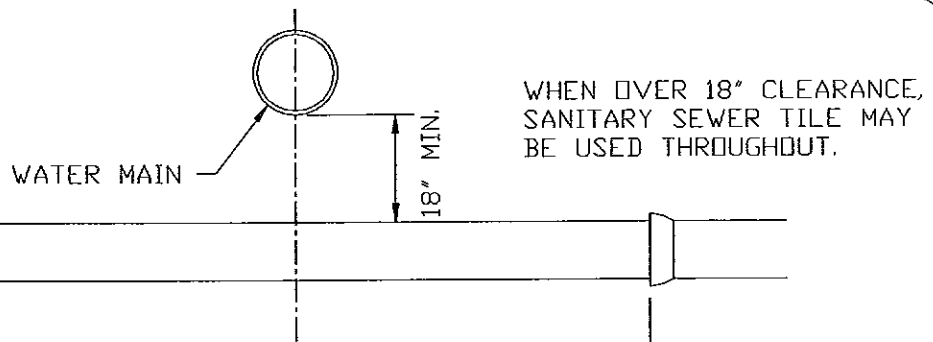
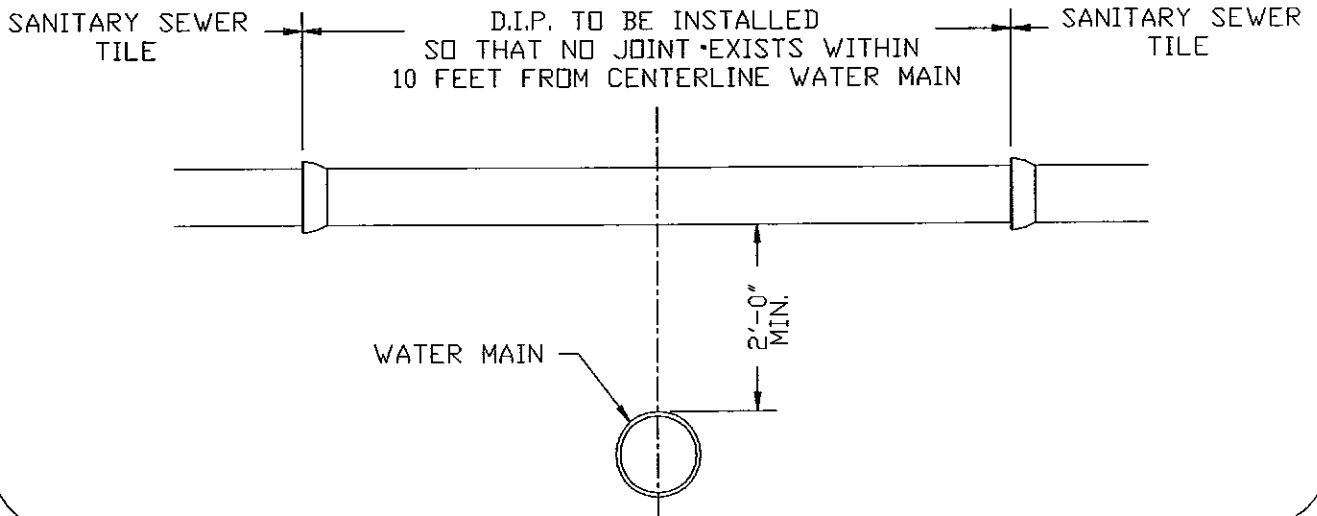

SANITARY SEWER TILE — CAST IRON PIPE TO BE INSTALLED SO THAT NO JOINT EXISTS WITHIN 10 FEET FROM CENTERLINE WATER MAIN — SANITARY SEWER TILE

SANITARY SEWER CROSSING UNDER WATER MAIN

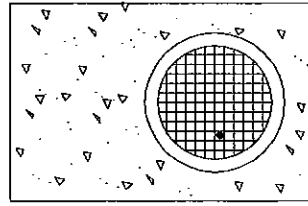

Section A - A

NOTE:
Deeter Cleanout Ring
& Solid Cover (Heavy
Duty - 1810)
or Equal

Top of Casting Elev. to be
Established in the Field by
the Engineer.

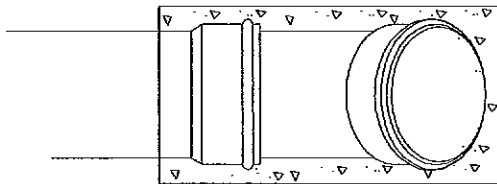
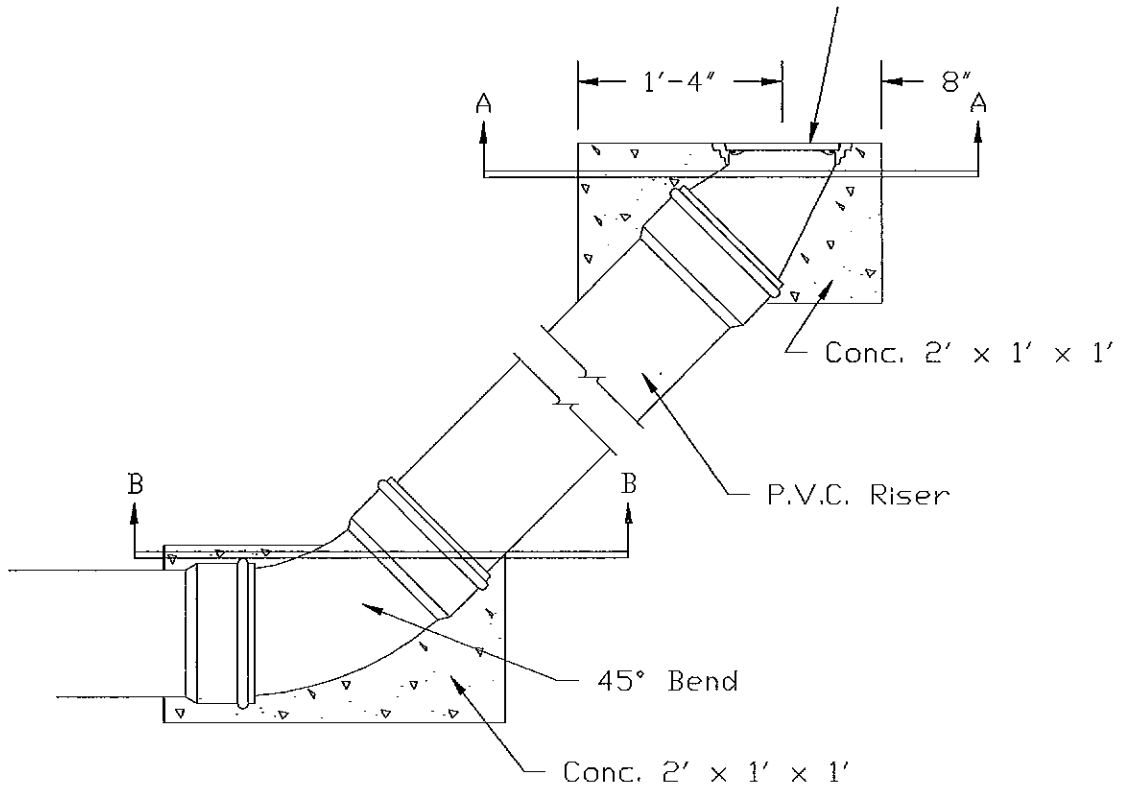

Section B - B

TYPICAL CLEANOUT

